

## Ultra Low Power 5V Boost Converter, 20V Linear Charger and Fuel Gauge All-in-One Solution for TWS Charge Cradle

### DESCRIPTION

ETA9085 is an all-in-one solution for TWS charge cradle. It includes a 20V single cell Li+ battery linear charger, a 5V Boost synchronous converter with true-shutoff function and a Fuel Gauge with LED indication. The linear charger is fully integrated with constant current (CC) / constant voltage (CV) control module and a charge FET. It has a pre-charge function for trickle charging a deeply discharged battery and its fast charge current can be programmed by an external resistor. In CV charge stage, charging will be terminated when the charge current drops to 1/10 of the programmed value. The integrated low power 5V Boost converter is capable of delivering 0.5A current at 5V output. It can be shut down by pulling the ENBST pin low. The true shut down feature disconnect output from the BAT thereby further decreasing the system standby power. Its 1.0MHz switching frequency allows a very small external inductor with inductance as low as 2.2uH. A fuel gauge also drives 4 LEDs for battery level indication. ETA9085 is ideal for applications such as a TWS charging cradle that requires low standby power and small PCB space.

ETA9085 is housed in a ESSOP10/DFN3x3-10 package

### FEATURES

- ◆ Ultra low boost standby  $I_q$ ,  $I_{bat} < 10\mu A$
- ◆ 20V Charge input standoff voltage
- ◆ 4.2V/4.35V charge termination voltage
- ◆ Charge current programmable
- ◆ Boost Output Disconnect and SCP
- ◆ 5V/0.5A Output Power
- ◆ Up to 96% Efficiency for boost
- ◆ Fuel Gauge and LED indicators
- ◆ NTC thermistor input
- ◆ Logic Control Shutdown
- ◆ Thermal shutdown
- ◆ ESSOP10/ DFN3x3-10 Package

### APPLICATIONS

- ◆ TWS BT earbuds charge case
- ◆ Bluetooth application
- ◆ Battery powered IOT module
- ◆ Power Bank

### TYPICAL APPLICATION

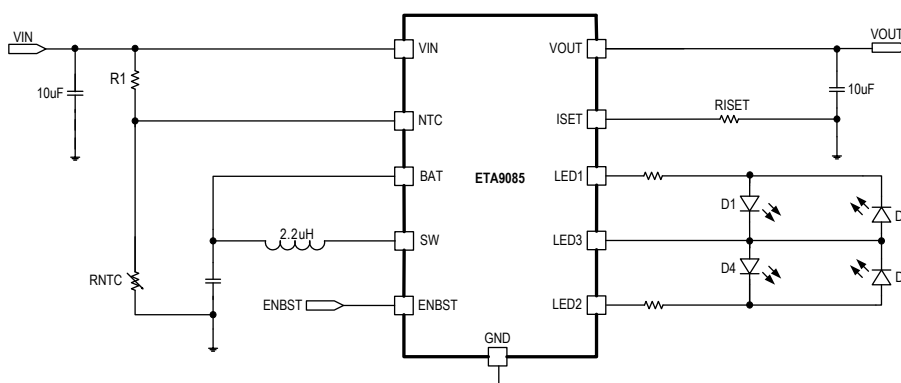

## ORDERING INFORMATION

PART No.	PACKAGE	TOP MARK	Pcs/Reel
ETA9085E10	ESSOP10	ETA9085 YWW2L	4000
ETA9085D3K	DFN3x3-10	ETA9085 YWW2L	5000

## PIN CONFIGURATION

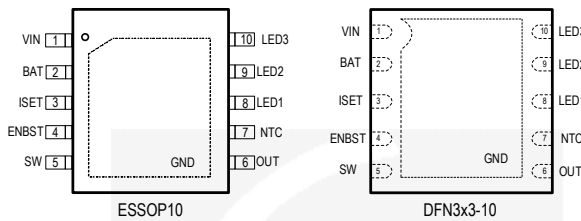

## ABSOLUTE MAXIMUM RATINGS

(Note: Exceeding these limits may damage the device. Exposure to absolute maximum rating conditions for long periods may affect device reliability.)

VIN, NTC Voltage	-0.3V to 20V
ALL Other PIN Voltage	-0.3V to 6V
SW to ground current	Internally limited
Operating Temperature Range	-40°C to 85°C
Storage Temperature Range	-55°C to 150°C
Thermal Resistance	$\theta_{JA}$ $\theta_{JC}$
ESSOP10	40      10      °C/W
DFN3x3-10	50      12      °C/W
Lead Temperature (Soldering 10sec)	260°C
ESD HBM (Human Body Mode)	2KV
ESD CDM (Charged Device Mode)	2KV
LATCHUP	200mA

## ELECTRICAL CHARACTERISTICS

( $V_{BAT}=3.8V$ ,  $V_{IN}=5V$ ,  $V_{OUT} = 5V$ , unless otherwise specified. Typical values are at  $T_A = 25^\circ C$ .)

PARAMETER	CONDITIONS	MIN	TYP	MAX	UNITS
<b>Linear Charger</b>					
Input Standoff Voltage				20	V
Input Over-Voltage Protection Voltage	VIN rising, HYS=0.3V		6.8		V
Input Voltage Range for Charging		4		6	V
VIN Under-voltage Lockout Threshold	VIN rising, HYS=0.5V, enable charging		4.5		V
Input Supply Current	Charge Mode		3		mA
	Standby Mode (Charge Terminated)		2		mA
Regulated VBATT Voltage	Charge Terminated Voltage	4.16	4.2	4.24	V
	Charge Terminated Voltage, add 30K RES between LED2 and GND	4.31	4.35	4.39	V

PARAMETER	CONDITIONS	MIN	TYP	MAX	UNITS
BAT Pin Current	RISET = 1K, Current Mode		1000		mA
	RISET = 2K, Current Mode		500		mA
Trickle Charge Current	VBAT < VTRIKL, RISET = 2K		50		mA
Trickle Charge Threshold Voltage	VBAT Rising		3		V
Trickle Charge Hysteresis Voltage			200		mV
VIN-VBAT Lockout Threshold Voltage	VIN from Low to High		100		mV
	VIN from High to Low		50		mV
Termination Current Threshold	RISET = 2K		50		mA
ISET Pin Voltage	Current Mode, VBAT=4V		1		V
Recharge BAT Threshold Voltage	Vtermination - VRECHRG		150		mV
Thermal regulation When Charging			100		°C
Vhold	VIN Voltage start to reduce charging current, when select Vtermination=4.2V		4.45		V
	VIN Voltage start to reduce charging current, when select Vtermination=4.35V		4.55		V
Power FET "ON" Resistance (Between VIN and BAT)			0.5		ohm
Soft-Start Time	IBAT = 0 to IBAT = 1000V/RISET		200		µs
NTC Threshold, Cold	Charger Suspended		66		% VIN
NTC Threshold, Hot	Charger Suspended		35		% VIN
NTC Threshold Hysteresis			1		% VIN
NTC Input Leakage			0	1	µA
<b>Boost Converter</b>					
Quiescent Current at BAT	Vbat=4V		8	15	µA
Shutdown Supply Current at BAT	V <sub>ENBST</sub> =GND		3	5	µA
VBAT Startup Voltage	VBAT rising, HYS=0.2V		3.2		V
VBAT Unlock Voltage	When boost is lock by low VBAT		3.55		V
LOW BAT WARNING Voltage	HYS=100mV, Rising		3.15		V
Output Voltage at 5V		4.85	5	5.15	V
Switching Frequency			1.0		MHz
NMOS Switch On Resistance	I <sub>SW</sub> =100mA		100		mΩ
PMOS Switch On Resistance	I <sub>SW</sub> =100mA		100		mΩ
SW Leakage Current	V <sub>OUT</sub> =5.2V, V <sub>ENBST</sub> =GND, V <sub>SW</sub> =5.2V or V <sub>SW</sub> = 0V		0	10	µA
NMOS Switch Current Limit			0.9		A
Start-up Current Limit			0.5		A
Short Circuit Hiccup time	ON		24		ms

PARAMETER	CONDITIONS	MIN	TYP	MAX	UNITS
	OFF		168		ms
ENBST Input Current	V <sub>ENBST</sub> =5V or 0V	-5	0	5	μA
ENBST High Voltage	V <sub>OUT</sub> =5V	1.2			V
ENBST low Voltage	V <sub>OUT</sub> =5V			0.4	V
Thermal Shutdown	Rising, Hysteresis=20°C		140		°C

## PIN DESCRIPTION

PIN #	NAME	DESCRIPTION
1	VIN	Input Supply Voltage. Bypass with a 10μF ceramic capacitor to GND
2	BAT	Connected to the battery positive terminal. Bypass with a 10uF ceramic capacitor to GND
3	ISET	Charge current program pin. The charge current is programmed by connecting a 1% resistor (RISET), between ISET, to GND pin. The charge current can be calculated by using the following formula: $I_{BAT} = \frac{1}{R_{set}} \times 1000$
4	ENBST	Enable pin for the Boost converter. Leave this pin floating to enable the part, low to disable. Pulling high is not recommended.
5	SW	Inductor Connection. Connect an inductor Between SW and the regulator output.
6	OUT	Output pin. Bypass with a 10μF or larger ceramic capacitor closely between this pin and GND
7	NTC	Battery Temperature Monitoring input pin. It sets the valid temperature operating range for battery charging. Disable NTC by setting R1=10K, RNTC=10K
8	LED1	LED1 pin for driver LED
9	LED2	LED2 pin for driver LED
10	LED3	LED2 pin for driver LED
11	GND	GND

## TYPICAL CHARACTERISTICS

(Typical values are at  $T_A = 25^\circ\text{C}$  unless otherwise specified.)

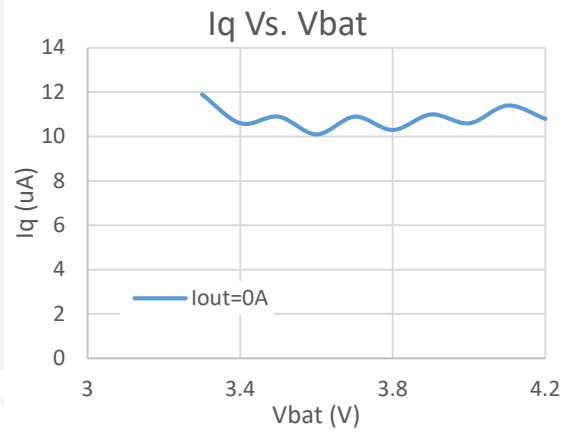
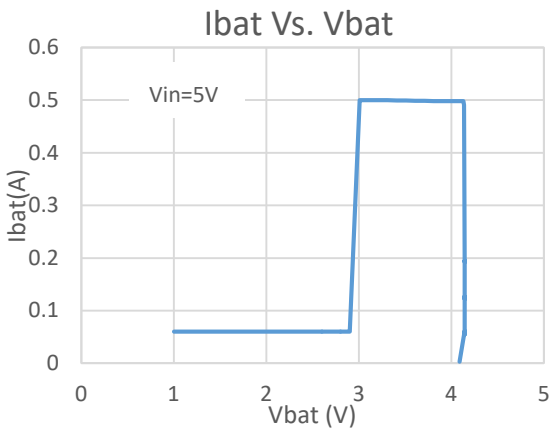
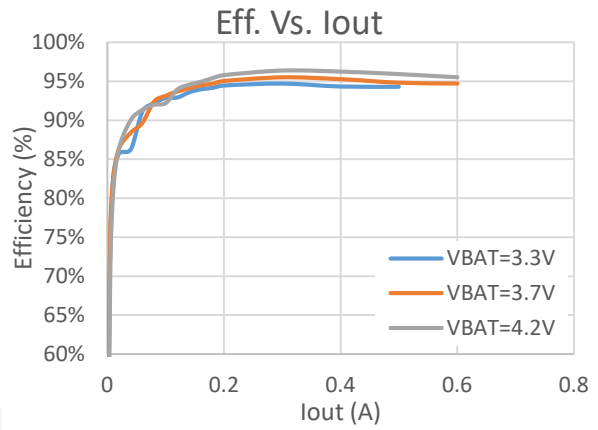
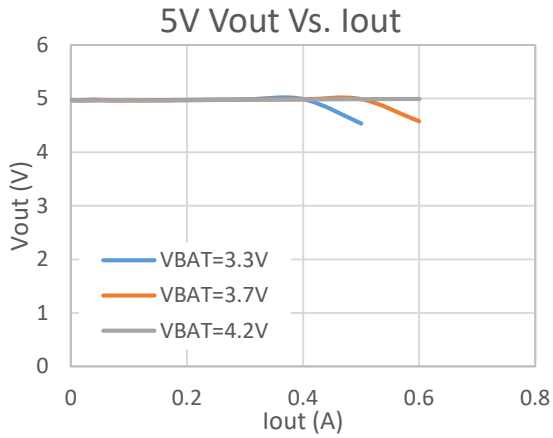

## FUNCTION BLOCK DIAGRAM

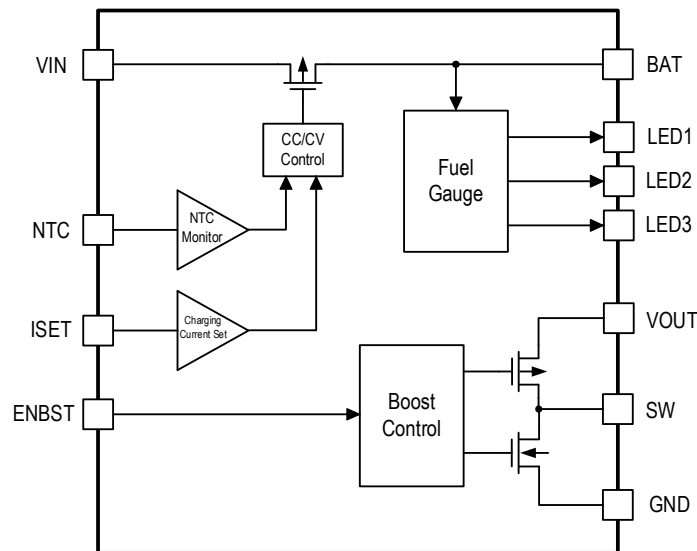

## APPLICATION INFORMATION

ETA9085 is an ultra low power 5V boost converter, 20V linear charger and fuel gauge all-in-one solution for TWS charge cradle, boost converter with true-shutoff function.

### Normal Charge Cycle

The ETA9085 initiates a charge cycle once the voltage at the VIN pin rises above the UVLO threshold level. A 1% precision resistor needs to be connected from the ISET pin to ground. If the voltage at the BAT pin is less than 3.0V, the charger enters trickle charge mode. In this mode, the charge current is reduced to nearly 1/10 the programmed value until the battery voltage is raised to a safe level for full current charging.

The charger switches to constant-current mode as the BAT pin voltage rises above 3.0V, the charge current is thus resumed to full programmed value. When the final VBAT voltage (4.2V or 4.35V) is reached, the ETA9085 enters constant-voltage mode and the charge current begins to decrease until it drops to 1/10 of the preset value and ends the charge cycle.

### Programming Charge Current

The charge current is programmable by setting the value of a precision resistor connected from the ISET pin to ground. The charge current out of the BAT pin can be using the following equation:

$$I_{BAT} = \frac{1}{R_{set}} \times 1000$$

### LED Display Mode

The ETA9085 use D1, D2, D3, D4 LEDS to show the battery voltage level.

Table 1 D1, D2, D3, D4 Battery Voltage Level Indicator

State	Battery Voltage Level(C)	D1	D2	D3	D4
Charging	C≤25%	1Hz flash	off	off	off
	25%<C≤50%	on	1Hz flash	Off	off
	50%<C≤75%	on	on	1Hz flash	off
	75%<C	on	on	on	1Hz flash
	Charging Done	on	on	on	on
Discharging	75%<C≤100%	on	on	on	on
	50%<C≤75%	on	on	on	Off
	25%<C≤50%	on	on	off	off
	3%<C≤25%	on	off	off	off
	C≤3%	1Hz flash	off	off	off

### *Charge Termination*

The ETA9085 keeps monitoring the ISET pin during the charging process. It terminates the charge cycle when the charge current falls to 1/10 the programmed value after the final VBAT voltage (4.2V or 4.35V) is reached. When the ISET pin voltage falls below 100mV for longer than tTERM (typically 180ms), charging is terminated. The charge current is latched off and the ETA9085 enters standby mode, where the input supply current drops to 2mA. (Note: C/10 termination is disabled in Vhold charging and thermal limiting modes).

During charging, the transient response of the circuit can cause the ISET pin to fall below 100mV temporarily before the battery is fully charged, thus can cause a premature termination of the charge cycle. A 180ms filter time on the termination comparator can prevent this from happening. Once the average charge current drops below 1/10 the programmed value, the ETA9085 terminates the charge cycle and ceases to provide any current through the BAT pin. In this state, all loads on the BAT pin must be supplied by the battery.

The ETA9085 constantly monitors the BAT pin voltage in standby mode and resume another charge cycle if this voltage drops below the recharge threshold. User can also manually restart a charge cycle in standby mode by removing and then reapplied the input voltage

### *High Temperature Fold-back*

Build-in feedback circuitry mechanism can reduce the value of the programmed charge current once the die temperature tends to rise above 100°C, hence prevents the temperature from further increase and ensure device safe operation.

### *Under-voltage Lockout (UVLO)*

Build-in under-voltage lockout circuit monitors the input voltage and keeps the charger in shutdown mode until VIN rises above the under-voltage lockout threshold. The UVLO circuit has a built-in hysteresis of 500mV. Furthermore, to protect against reverse current in the power MOSFET, the UVLO circuit keeps the charger in shutdown mode if VIN falls to within 50mV of the battery voltage for 3mS. If the UVLO comparator is tripped, the charger will not come out of shutdown mode until VIN rises 100mV above the battery voltage.

### *Automatic Recharge*

After the termination of the charge cycle, the ETA9085 constantly monitors the BAT pin voltage and starts a new charge cycle when the battery voltage falls below Recharge Voltage, keeping the battery at fully charged condition. ISET pin output enters a strong pull-down state during recharge cycles.

### *Battery Temperature Monitoring*

ETA9085 continuously monitors temperature by measuring the voltage of NTC pin. A negative or positive temperature coefficient thermistor and an external voltage divider typically develop this voltage. ETA9085 compares this voltage against its internal 66%VIN and 35%VIN thresholds to determine if charging is allowed. The temperature sensing circuit

is immune to any fluctuation in VIN, since both the external voltage divider and the internal thresholds 66%VIN and 35%VIN are referenced to VIN. If the NTC pin is connected to GND will disable the temperature-sensing feature.

### Ultra low current consumption at Light Load Boost Operation

Traditionally, a fixed constant frequency PWM DC/DC regulator always switches even when the output load is small. When energy is shuffling back and forth through the power MOSFETs, power is lost due to the finite RDSOns of the MOSFETs and parasitic capacitances. At light load, this loss is prominent and efficiency is therefore very low. ETA9085 employs a proprietary control scheme that improves efficiency in this situation by enabling the device into a power saving mode during light load and the no load quiescent current can be lower than 10µA.

### Output (5V OUT pin) Short-Circuit Protection

Unlike most step-up converters, the ETA9085 allows for short circuits on the output. In the event of a short circuit, the device first turns off the NMOS when the sensed current reaches the current limit. When OUT drops below VBAT, the device then enters a linear charge period with the current limited same as with the start-up period. In addition, the thermal shutdown circuits disable switching if the die temperature rises above 140°C.

## PCB GUIDELINES

Keep the power devices as close to the chip as possible to achieve the smallest power loop area, which leads to the best EMI performance; Cin is always placed nearest to Vin and GND

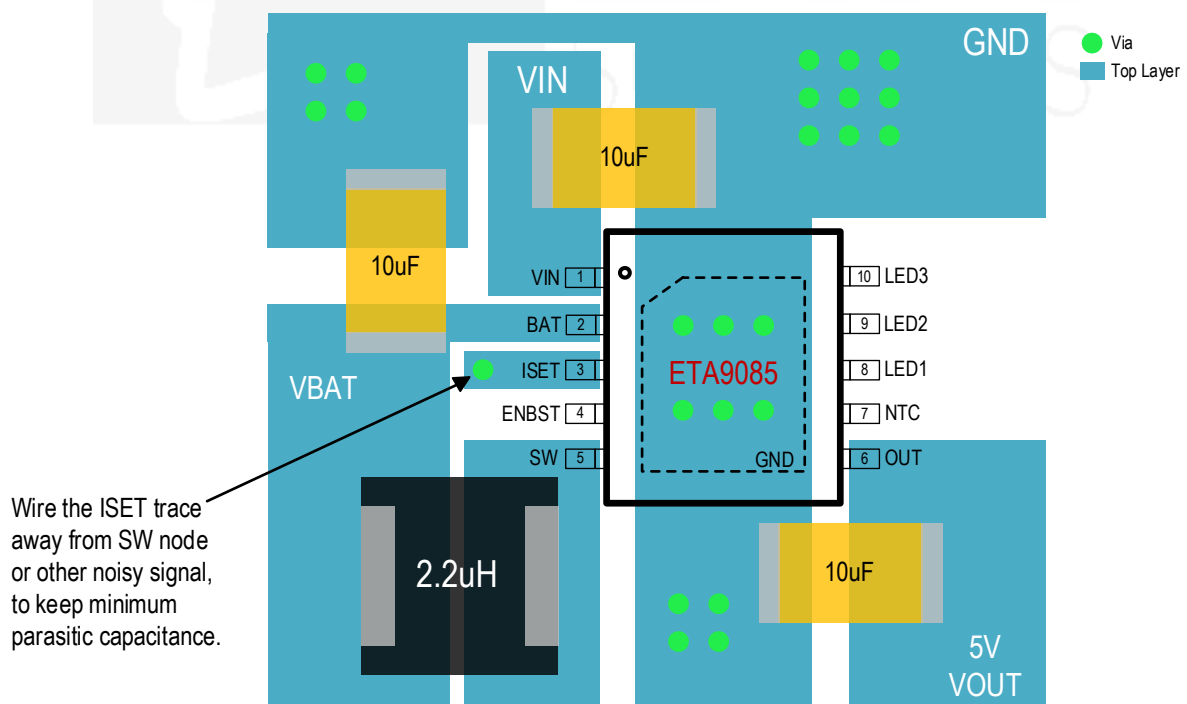



## PACKAGE OUTLINE

Package: ESSOP10

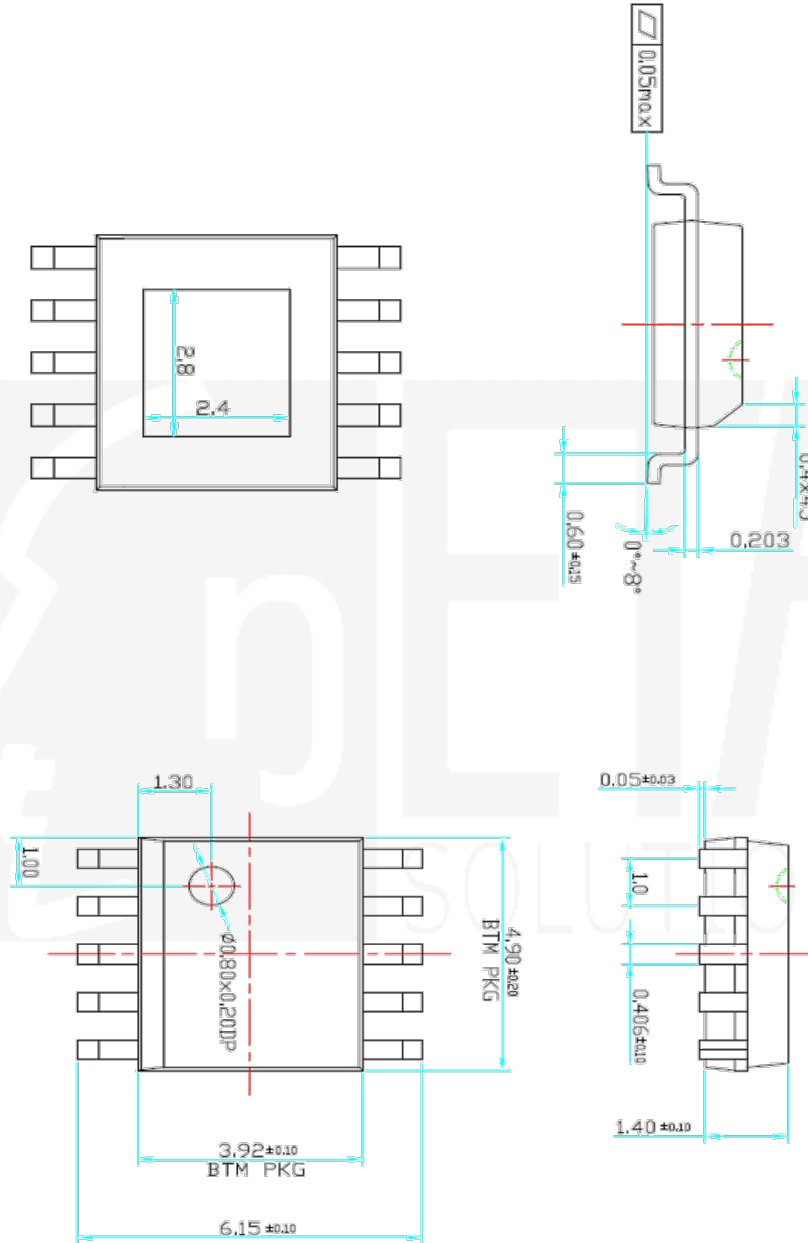

PACKAGE OUTLINE

Package: DFN3x3-10

