

## Features

- Internal start-up circuit with 500V rating and low frequency operation achieves **140mW input at no load**.
- **Small Output Capacitance** : Linearly reduced frequency for lighter load causes small ripple voltage.
- Suitable for Low Noise and High Efficiency about 90%
- Line-up of 3 types for maximum frequency and OLP
  - 5530: 65kHz max., 16Vmax.-VCC, Auto-restart OLP
  - 5531: 130kHz max., 28Vmax.-VCC, Auto-restart OLP
  - 5532: 130kHz max., 28Vmax.-VCC, Timer-Latched OLP
- High ability of driving Power MOSFET ( High / Low side : 17 ohm / 3.5 ohm ) : available to 200W output
- **Vcc rating 28V allows no series regulator for auxiliary winding to clamp Vcc voltage for FA5531/32.**
- 1ms Fixed Soft Start time
- Timer Latched Over-Voltage Protection of 16V/28V Vcc
- 8 pins package ( DIP/SO )

**Usage : Notebook PC, LCD Monitor, LCD-TV etc.**

## FA5531 Block Diagram

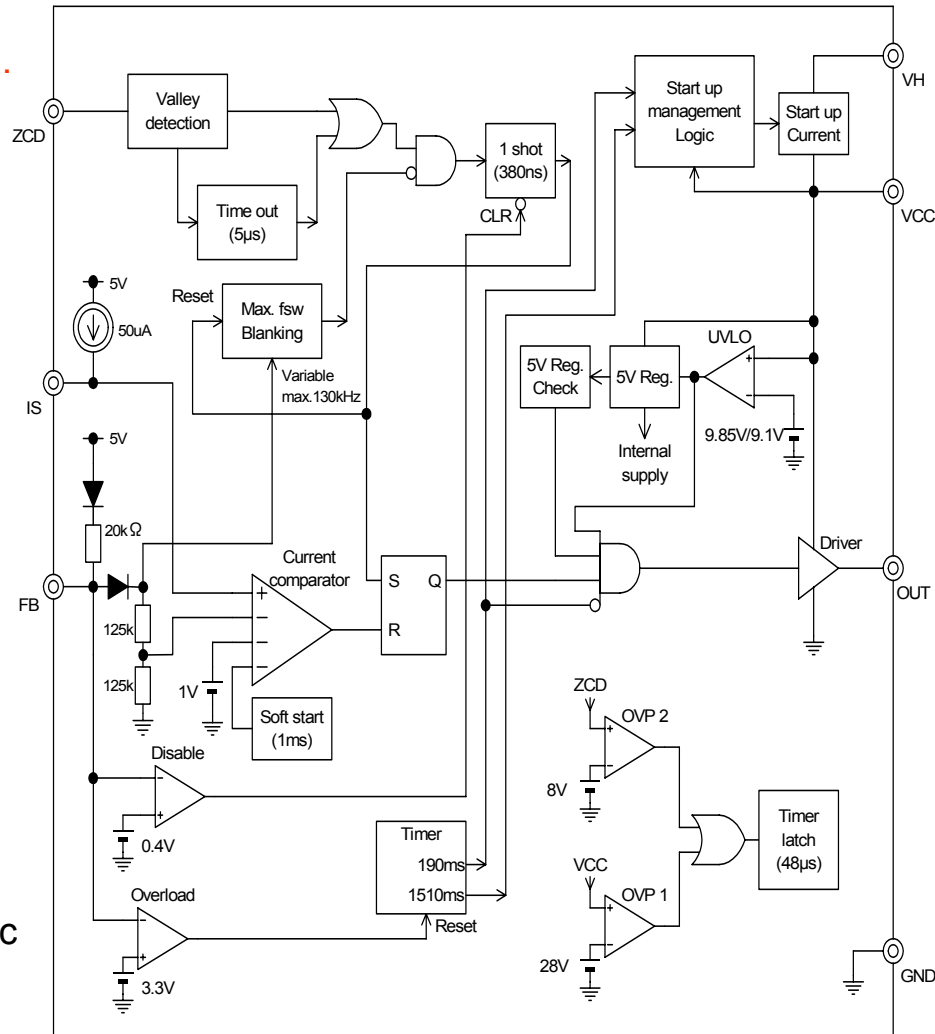



## Switching Frequency vs. Output Power

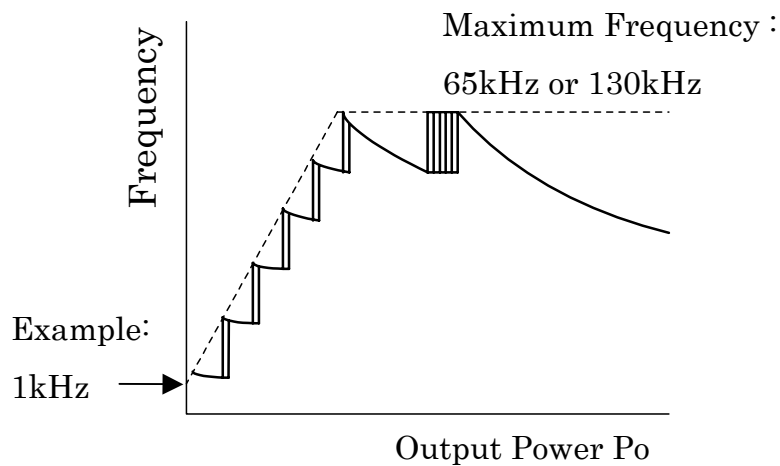

## Timing Chart ( FA5531/32 )

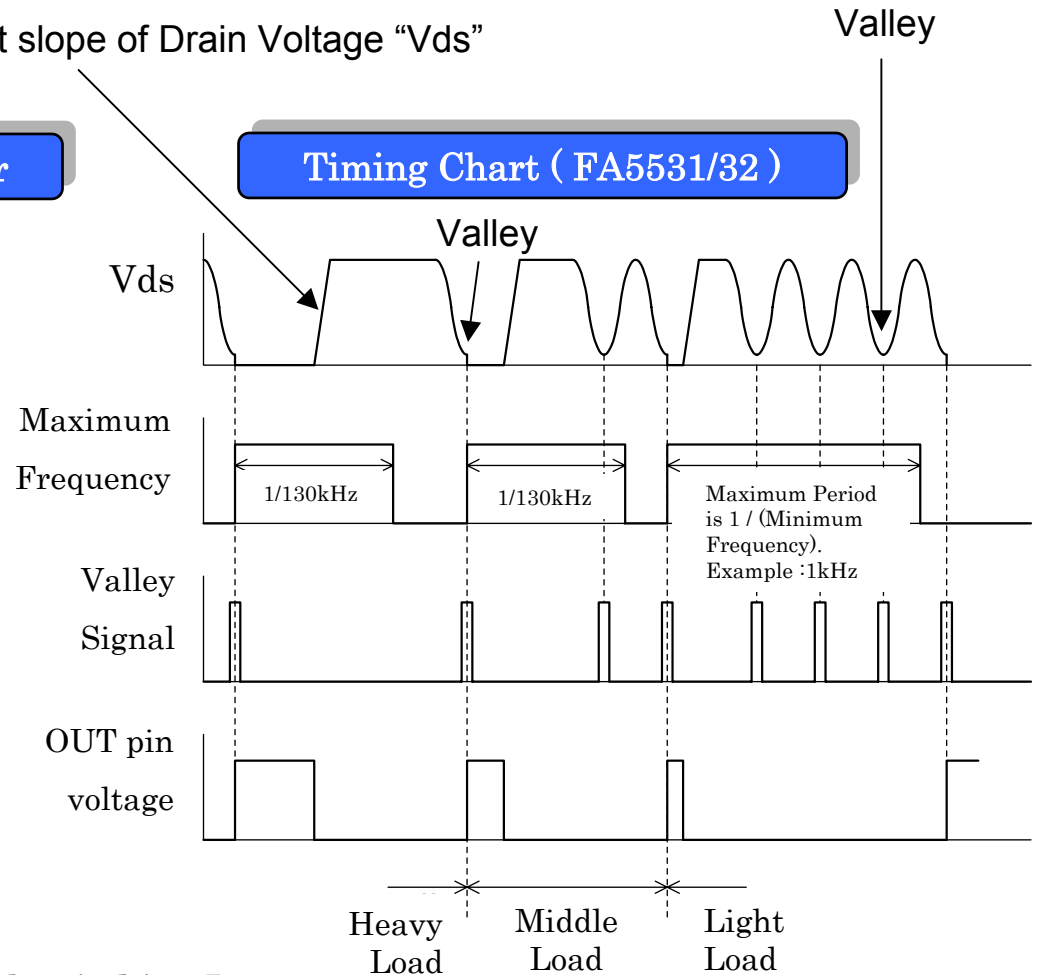

- Low frequency switching such as 1kHz at light load reduces standby power.
- Maximum frequency limits EMI noise and switching Loss.
- Switching at Valley of Vds : Turn-ON Loss and Noise are very small.
- Low dV/dt of Vds at Turn-OFF by a capacitor connected between Drain and Source of Power MOSFET : Turn-OFF Loss and Noise are also very small.

## Demo Board Data

- Demo Board Specification  
Input Range : 80Vac to 264Vac  
Output Rating : 95W ( 19V / 5A )
- Demo Board Data  
60mW to 140mW at no load, 0.9kHz  
Efficiency : 86 to 91% ( 20W to 95W )  
→ satisfies the standard of energy star

