



Winstar Display Co., LTD 華凌光電股份有限公司



住址: 407 台中市中清路 163 號
No.163 Chung Ching RD.,
Taichune, Taiwan, R.O.C

WEB: <http://www.winstar.com.tw>
E-mail: winstar@winstar.com.tw
Tel:886-4-24262208 Fax : 886-4-24262207

SPECIFICATION

CUSTOMER : _____

MODULE NO.: WG16032A-YGB-V

<p style="text-align: center;">APPROVED BY: (FOR CUSTOMER USE ONLY)</p>	
--	--

SALES BY	APPROVED BY	CHECKED BY	PREPARED BY
ISSUED DATE:			

Contents

- 1.Module Classification Information
- 2.Precautions in use of LCD Modules
- 3.General Specification
- 4.Absolute Maximum Ratings
- 5.Electrical Characteristics
- 6.Optical Characteristics
- 7.Interface Description
- 8.Contour Drawing & Block Diagram
- 9.Function Description
- 10.Commands Description
- 11.Timing Characteristics
- 12.Quality Assurance
- 13.Reliability
- 14.Backlight Information

1.Module Classification Information

$\frac{W}{\bullet}$ $\frac{G}{,}$ $\frac{1}{f}$ $\frac{160}{}$ $\frac{32}{}$ $\frac{A}{"}$ - $\frac{Y}{\dots}$ $\frac{G}{\dagger}$ $\frac{B}{\ddagger}$ - $\frac{V}{\wedge}$

• Brand : WINSTAR DISPLAY CORPORATION

' Display Type : H→Character Type, G→Graphic Type

f Display Font : 160* 32 Dots

" Model serials no.

... Backlight Type : N→Without backlight

A→LED, Amber

B→EL, Blue green

R→LED, Red

D→EL, Green

O→LED, Orange

W→EL, White

G→LED, Green

F→CCFL, White

Y→LED, Yellow Green

† LCD Mode : B→TN Positive, Gray T→FSTN Negative

N→TN Negative,

G→STN Positive, Gray

Y→STN Positive, Yellow Green

M→STN Negative, Blue

F→FSTN Positive

‡ LCD Polarize Type/ Temperature range/ View A→Reflective, N.T, 6:00 H→Transflective, W.T,6:00

direction	D→Reflective, N.T, 12:00	K→Transflective, W.T,12:00
	G→Reflective, W. T, 6:00	C→Transmissive, N.T,6:00
	J→Reflective, W. T, 12:00	F→Transmissive, N.T,12:00
	B→Transflective, N.T,6:00	I→Transmissive, W. T, 6:00
	E→Transflective, N.T.12:00	L→Transmissive, W.T,12:00
^ Special Code	V : Built in Negative Voltage	

2. Precautions in use of LCD Modules

- (1) Avoid applying excessive shocks to the module or making any alterations or modifications to it.
- (2) Don't make extra holes on the printed circuit board, modify its shape or change the components of LCD module.
- (3) Don't disassemble the LCM.
- (4) Don't operate it above the absolute maximum rating.
- (5) Don't drop, bend or twist LCM.
- (6) Soldering: only to the I/O terminals.
- (7) Storage: please storage in anti-static electricity container and clean environment.

3. General Specification

Item	Dimension	Unit
Number of Characters	160 x 32 dots	-
Module dimension	78.2 x 55.0 x 14.6(MAX)	mm
View area	72.0 x 22.0	mm
Active area	70.36 x 19.47	mm
Dot size	0.40 x 0.56	mm
Dot pitch	0.44 x 0.61	mm
LCD type	STN, Positive, Transflective, Gray	
Duty	1/32	
View direction	6 o'clock	
Backlight Type	LED Yellow Green	

4. Absolute Maximum Ratings

Item	Symbol	Min	Typ	Max	Unit
Operating Temperature	T_{OP}	0	-	+50	°C
Storage Temperature	T_{ST}	-10	-	+60	°C
Input Voltage	V_I	0	-	V_{DD}	V
Supply Voltage For Logic	V_{DD}	0	-	6.7	V
Supply Voltage For LCD	$V_{DD}-V_{LCD}$	0	-	-10	V

Supply Voltage For LCD	V_{EE}	-	-5V	-	V
------------------------	----------	---	-----	---	---

5. Electrical Characteristics

Item	Symbol	Condition	Min	Typ	Max	Unit
Supply Voltage For Logic	$V_{DD}-V_{SS}$	-	4.75	5.0	5.25	V
Supply Voltage For LCD	$V_{DD}-V_0$	$T_a=-20^{\circ}\text{C}$	-	-	6.0	V
		$T_a=25^{\circ}\text{C}$	-	5.5	-	V
		$T_a=+70^{\circ}\text{C}$	5.0	-	-	V
Input High Volt.	V_{IH}	-	$0.7V_{DD}$	-	V_{DD}	V
Input Low Volt.	V_{IL}	-	0	-	$0.3V_{DD}$	V
Output High Volt.	V_{OH}	-	2.4	-	-	V
Output Low Volt.	V_{OL}	-	-	-	0.4	V
Supply Current	I_{DD}	-	-	5		mA

6. Optical Characteristics

Item	Symbol	Condition	Min	Typ	Max	Unit
View Angle	$(V)\theta$	$CR \geq 2$	10	-	105	deg
	$(H)\phi$	$CR \geq 2$	-30	-	30	deg

Contrast Ratio	CR	-	3	-	-	-
Response Time	T rise	-	-	100	150	ms
	T fall	-	-	100	150	ms

Definition of Operation Voltage (Vop)

Definition of Response Time (Tr, Tf)

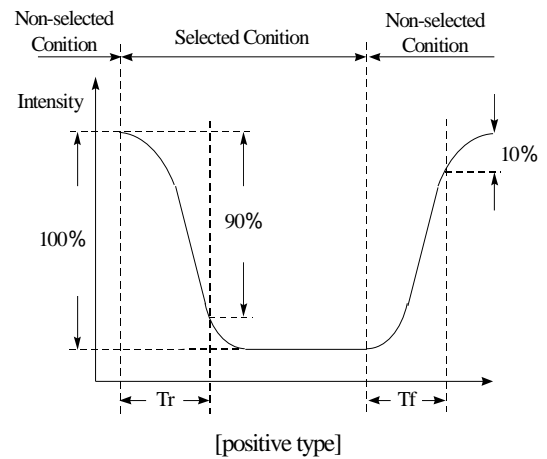
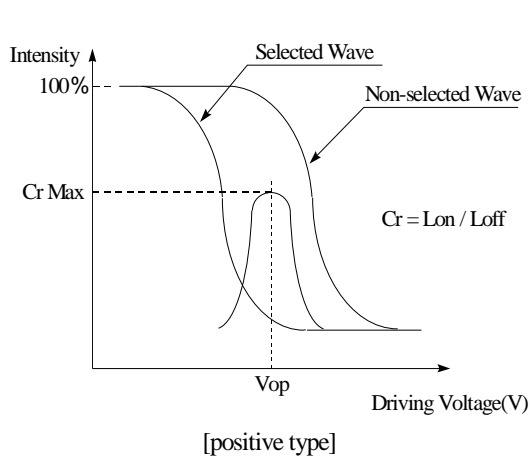

Conditions :

Operating Voltage : Vop Viewing Angle(θ , φ) : 0° , 0°

Frame Frequency : 64 HZ Driving Waveform : 1/N duty , 1/a bias

Definition of viewing angle($CR \geq 2$)

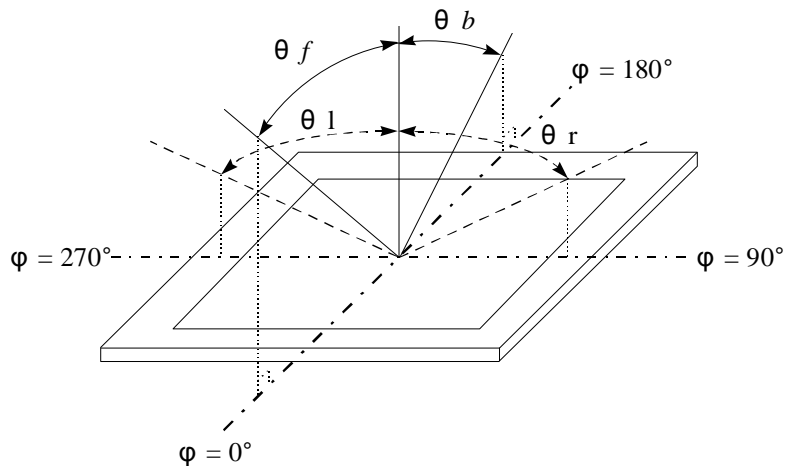

7. Interface Description

Pin No.	Symbol	Level	Description
---------	--------	-------	-------------

1	V _{ss}	0V	Ground
2	V _{dd}	5V	Power supply for logic
3	V _o	(Variable)	Operating voltage for LCD
4	A0	H/L	H : Data L : Instruction
5	CS1	H/L	Cs1=0 cs2=0 chip select signal for s1~s61
6	CS2	H/L	Cs1=0 cs2=1 chip select signal for s62~s141 Cs1=1 cs2=0 chip select signal for s142~s168
7	CL		Clock 2KHz
8	E	H,H \bar{e} L	Chip Enable signal
9	R/W	H/L	H : Read ; L : Write
10	DB0	H/L	Data bus
11	DB1	H/L	Data bus
12	DB2	H/L	Data bus
13	DB3	H/L	Data bus
14	DB4	H/L	Data bus
15	DB5	H/L	Data bus
16	DB6	H/L	Data bus
17	DB7	H/L	Data bus
18	RST	H/L	H -> L: The LCM be reset
19	A/VEE		Negative Voltage -5v
20	K		NC

8. Contour Drawing & Block Diagram

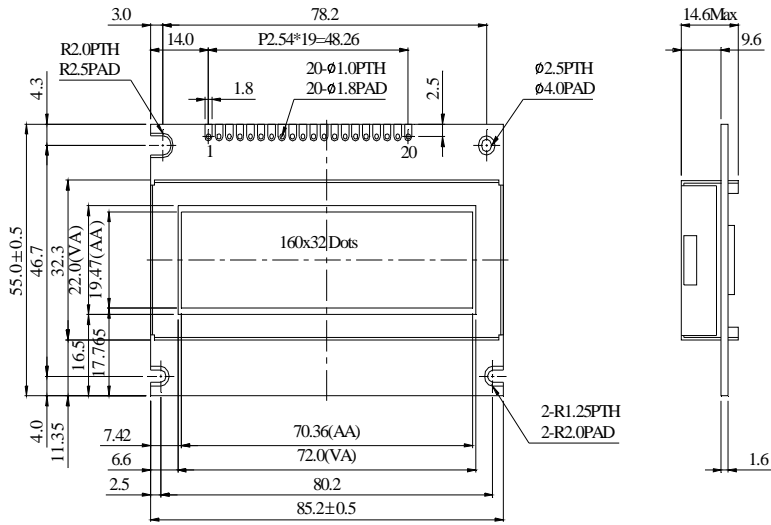

PIN NO.	SYMBOL
1	Vss
2	Vdd
3	Vo
4	A0
5	CS1
6	CS2
7	CL
8	E
9	R/W
10	DB0
11	DB1
12	DB2
13	DB3
14	DB4
15	DB5
16	DB6
17	DB7
18	RST
19	A/VEE
20	K

LED B/L

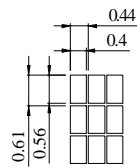

DOT SIZE
SCALE 10/1

The non-specified tolerance of dimension is $\sqrt[3]{0.3}$ mm.

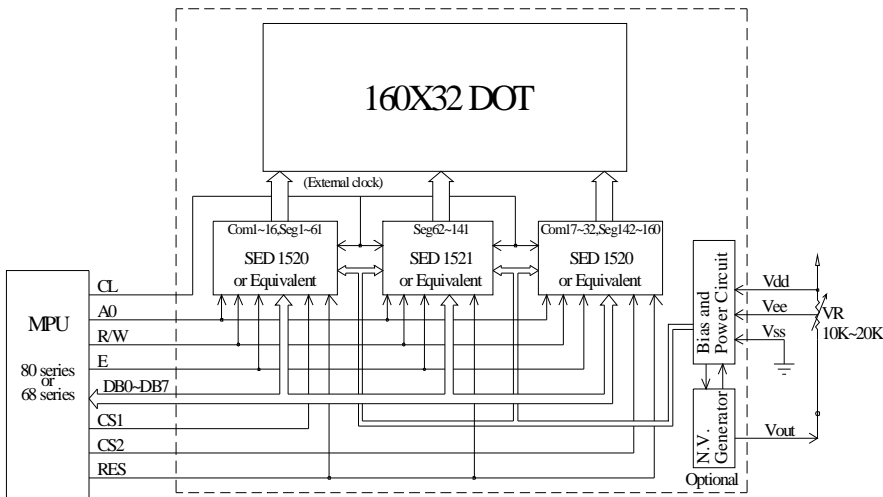

External contrast adjustment.

LED B/L Drive Method

1. Drive from A,K

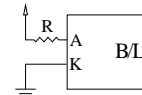

3. Drive from Vdd, Vss

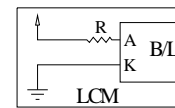

(Contrast performance may go down.)

9. Function Description

Block Diagram

This 160×32 dots LCD Module built in two SED 1520 LSI controller.

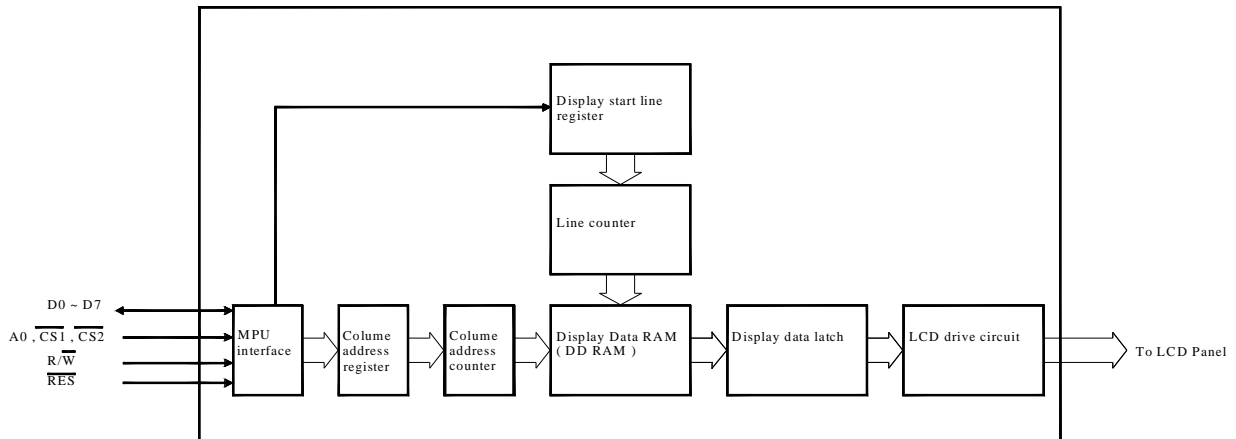

MPU interface

The SED 1520 controller transfers data via 8-bit bidirectional data buses (D0 to D7), it can fit any MPU if it corresponds to SED 1520 Read and Write Timing Characteristics.

Data transfer

The SED1520 driver uses the A0, E and R/W signals to transfer data between the system MPU and internal registers, The combinations used are given in the table below.

A0	R/W	Function
1	1	Read display data
1	0	Write display data
0	1	Read status
0	0	Write to internal register (command)

Busy flag

When the Busy flag is logical 1, the SED1520 series is executing its internal operations. Any

command other than Status Read is rejected during this time. The Busy flag is output at pin D7 by the Status Read command. If an appropriate cycle time (t_{CYC}) is given, this flag needs not be checked at the beginning of each command and, therefore, the MPU processing capacity can greatly be enhanced.

Display Start Line and Line Count Registers

The contents of this register form a pointer to a line of data in display data RAM corresponding to the first line of the display (COM0), and are set by the Display Start Line command.

Column Address Counter

The column address counter is a 7-bit presentable counter that supplies the column address for MPU access to the display data RAM. See Figure 1. The counter is incremented by one every time the driver receives a Read or Write Display Data command. Addresses above 50H are invalid, and the counter will not increment past this value. The contents of the column address counter are set with the Set Column Address command.

Display Data RAM

The display data RAM stores the LCD display data, on a 1-bit per pixel basis. The relationship between display data, display address and the display is shown in Figure 1

Page Register

The page register is a 2-bit register that supplies the page address for MPU access to the display data RAM. See Figure 1. The contents of the page register are set by the Set Page Register command.

Figure 1.

Display Data RAM Address

Page address	DATA	Line address	Common output		
D1, D2 = 0, 0	D0	00H	COM0		
	D1	01H	COM1		
	D2	02H	COM2		
	D3	03H	COM3		
	D4	04H	COM4		
	D5	05H	COM5		
	D6	06H	COM6		
	D7	07H	COM7		
0, 1	D0	08H	COM8		
	D1	09H	COM9		
	D2	0AH	COM10		
	D3	0BH	COM11		
	D4	0CH	COM12		
	D5	0DH	COM13		
	D6	0EH	COM14		
	D7	0FH	COM15		
1, 0	D0	10H	COM16		
	D1	11H	COM17		
	D2	12H	COM18		
	D3	13H	COM19		
	D4	14H	COM20		
	D5	15H	COM21		
	D6	16H	COM22		
	D7	17H	COM23		
1, 1	D0	18H	COM24		
	D1	19H	COM25		
	D2	1AH	COM26		
	D3	1BH	COM27		
	D4	1CH	COM28		
	D5	1DH	COM29		
	D6	1EH	COM30		
	D7	1FH	COM31		
Column address	ADC	D0=0	4FH	00H	80
		D0=1	4EH	01H	79
		seg pin	4DH	02H	78
			3AH		59
			3BH		60
			3CH		61

SEDI520: 00H to 17H

SEDI521: 00H to 1FH

10. Commands Descriptions

Summary

Command	Code											Function
	A0	RD	WR	D7	D6	D5	D4	D3	D2	D1	D0	
Display ON/OFF	0	1	0	1	0	1	0	1	1	1	0/1	Turns display on or off. 1:ON, 0:OFF
Display start line	0	1	0	1	1	0	Display start address (0 to 31)				Specifies RAM line corresponding to top line of display.	
Set page address	0	1	0	1	0	1	1	1	0	Page (0 to 3)		Sets display RAM page in page address register.
Set column (segment) address	0	1	0	0	Column address (0 to 79)							Sets display RAM column address in column address register.
Read status	0	0	1	Busy	ADC	ON/OFF	Reset	0	0	0	0	Reads the following status: BUSY 1:Busy 0:Ready ADC 1:CCW output 0:CW output ON/OFF 1:Display off 0: Display on RESET 1:Being reset 0:Normal
Write display data	1	1	0	Write data								Writes data from data bus into display RAM.
Read display data	1	0	1	Read data								Reads data from display RAM into data bus.
Select ADC	0	1	0	1	0	1	0	0	0	0	0/1	0:CCW output, 1:CW output
Static drive ON/OFF	0	1	0	1	0	1	0	0	1	0	0/1	Selects static driving operation. 1:Static drive, 0:Normal driving
Select duty	0	1	0	1	0	1	0	1	0	0	0/1	Selects LCD duty cycle 1:1/32, 0:1/16
Read-Modify-Write	0	1	0	1	1	1	0	0	0	0	0	Read-modify-write ON
End	0	1	0	1	1	1	0	1	1	1	0	Read-modify-write OFF
Reset	0	1	0	1	1	1	0	0	0	1	0	Software reset

Table 1

Table 1 is the command table. The SED 1520 series identifies a data bus using a combination of A0 and R/W (RD or WR) signals. As the MPU translates a command in the internal timing

only (independent from the external clock), its speed is very high. The busy check is usually not required.

Display ON/OFF

A ₀	R/W	D ₇	D ₆	D ₅	D ₄	D ₃	D ₂	D ₁	D ₀
0	0	1	0	1	0	1	1	1	D

AEH, AFH

This command turns the display on and off.

D=1: Display ON

D=0: Display OFF

Display Start Line

This command specifies the line address shown in Figure 1 and indicates the display line that corresponds to COM0. The display area begins at the specified line address and continues in the line address increment direction. This area having the number of lines of the specified display duty is displayed. If the line address is changed dynamically by this command, the vertical smooth scrolling and paging can be used.

A ₀	R/W	D ₇	D ₆	D ₅	D ₄	D ₃	D ₂	D ₁	D ₀
0	0	1	1	0	A ₄	A ₃	A ₂	A ₁	A ₀

C0H to DFH

This command loads display start line register.

A ₄	A ₃	A ₂	A ₁	A ₀	Line Address
0	0	0	0	0	0
0	0	0	0	1	1
		:			:
		:			:
1	1	1	1	1	31

See Figure 1.

Set Page Address

This command specifies the page address that corresponds to the low address of the display data RAM when it is accessed by the MPU. Any bit of the display data RAM can be accessed when its page address and column address are specified. The display status is not

changed even when the page address is changed.

A ₀	R/W	D ₇	D ₆	D ₅	D ₄	D ₃	D ₂	D ₁	D ₀
0	0	1	0	1	1	1	0	A ₁	A ₀

B8H to BBH

See Figure 1

Set Column Address

This command specifies a column address of the display data RAM. When the display data RAM is accessed by the MPU continuously, the column address is incremented by 1 each time it is accessed from the set address. Therefore, the MPU can access to data continuously. The column address stops to be incremented at address 80, and the page address is not changed continuously.

A ₀	R/W	D ₇	D ₆	D ₅	D ₄	D ₃	D ₂	D ₁	D ₀	
0	0	0	A ₆	A ₅	A ₄	A ₃	A ₂	A ₁	A ₀	00H to 4FH

This command loads the column address register.

A ₆	A ₅	A ₄	A ₃	A ₂	A ₁	A ₀	Column Address
0	0	0	0	0	0	0	0
0	0	0	0	0	0	1	1
			:				:
			:				:
1	0	0	1	1	1	1	79

Read Status

A ₀	R/W	D ₇	D ₆	D ₅	D ₄	D ₃	D ₂	D ₁	D ₀
0	1	BUSY	ADC	ON/OFF	RESET	0	0	0	0

Reading the command I/O register (A0=0) yields system status information.

·The busy bit indicates whether the driver will accept a command or not.

Busy=1: The driver is currently executing a command or is resetting. No new command will

be accepted.

Busy=0: The driver will accept a new command.

·The ADC bit indicates the way column addresses are assigned to segment drivers.

ADC=1: Normal. Column address $n \rightarrow$ segment driver n .

ADC=0: Inverted. Column address $79-u \rightarrow$ segment driver u .

·The ON/OFF bit indicates the current status of the display.

It is the inverse of the polarity of the display ON/OFF command.

ON/OFF=1: Display OFF

ON/OFF=0: Display ON

·The RESET bit indicates whether the driver is executing a hardware or software reset or if it is in normal operating mode.

RESET=1: Currently executing reset command.

RESET=0: Normal operation

Write Display Data

A ₀	R/W	D ₇	D ₆	D ₅	D ₄	D ₃	D ₂	D ₁	D ₀
1	0	Write data							

Writes 8-bits of data into the display data RAM, at a location specified by the contents of the column address and page address registers and then increments the column address register by one.

Read Display Data

A ₀	R/W	D ₇	D ₆	D ₅	D ₄	D ₃	D ₂	D ₁	D ₀
1	1	Read data							

Read 8-bits of data from the data I/O latch, updates the contents of the I/O latch with display data from the display data RAM location specified by the contents of the column address and page address registers and then increments the column address register.

After loading a new address into the column address register one dummy read is required before valid data is obtained.

Select ADC

A ₀	R/W	D ₇	D ₆	D ₅	D ₄	D ₃	D ₂	D ₁	D ₀
0	0	1	0	1	0	0	0	0	D

AOH A1H

This

command selects the relationship between display data RAM column addresses and segment drivers.

D=1: SEG0←column address 4FH,.....(inverted)

D=0: SEG0←column address 00H,.....(normal)

This command is provided to reduce restrictions on the placement of driver ICs and routing of traces during printed circuit board design. See Figure 1 for a table of segments and column addresses for the two values of D.

Static Drive ON/OFF

A ₀	R/W	D ₇	D ₆	D ₅	D ₄	D ₃	D ₂	D ₁	D ₀
0	0	1	0	1	0	0	1	0	D

A4H A5H

Forces display on and all common outputs to be selected.

D=1: Static drive on

D=0: Static drive off

Select Duty

A ₀	R/W	D ₇	D ₆	D ₅	D ₄	D ₃	D ₂	D ₁	D ₀
0	0	1	0	1	0	1	0	0	D

A8H A9H

This command sets the duty cycle of the LCD drive, Please set D=1, LCD duty cycle is 1/32 duty.

Read-Modify-Write

A ₀	R/W	D ₇	D ₆	D ₅	D ₄	D ₃	D ₂	D ₁	D ₀
0	0	1	1	1	0	0	0	0	0

E0H

This command defeats column address register auto-increment after data reads. The current contents of the column address register are saved. This mode remains active until an End command is received.

·Operation sequence during cursor display

When the End command is entered, the column address is returned to the one used during input of Read-Modify-Write command. This function can reduce the load of MPU when data change is repeated at a specific display area (such as cursor blinking).

* Any command other than Data Read or Write can be used in the Read-Modify-Write mode. However, the Column Address Set command cannot be used.

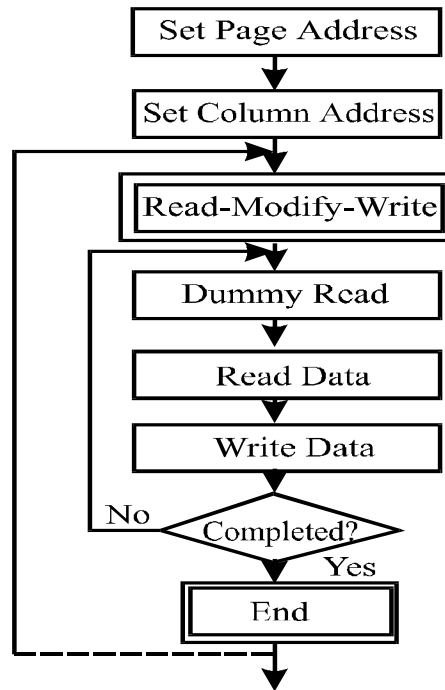

End

A ₀	R/W	D ₇	D ₆	D ₅	D ₄	D ₃	D ₂	D ₁	D ₀	
0	0	1	1	1	0	1	1	1	0	EEH

This command cancels read-modify-write mode and restores the contents of the column address register to their value prior to the receipt of the Read-Modify-Write command.

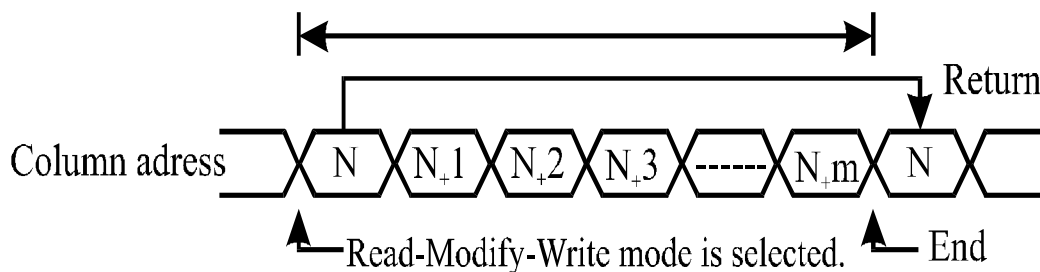

Reset

A ₀	R/W	D ₇	D ₆	D ₅	D ₄	D ₃	D ₂	D ₁	D ₀	
0	0	1	1	1	0	0	0	1	0	E2H

This command clears

- the display start line register.
- And set page address register to 3 page.

It does not affect the contents of the display data RAM.

When the power supply is turned on, a Reset signal is entered in the RES pin. The Reset command cannot be used instead of this Reset signal.

11. Timing Characteristics

MPU Bus Read/Write II (68-family MPU)

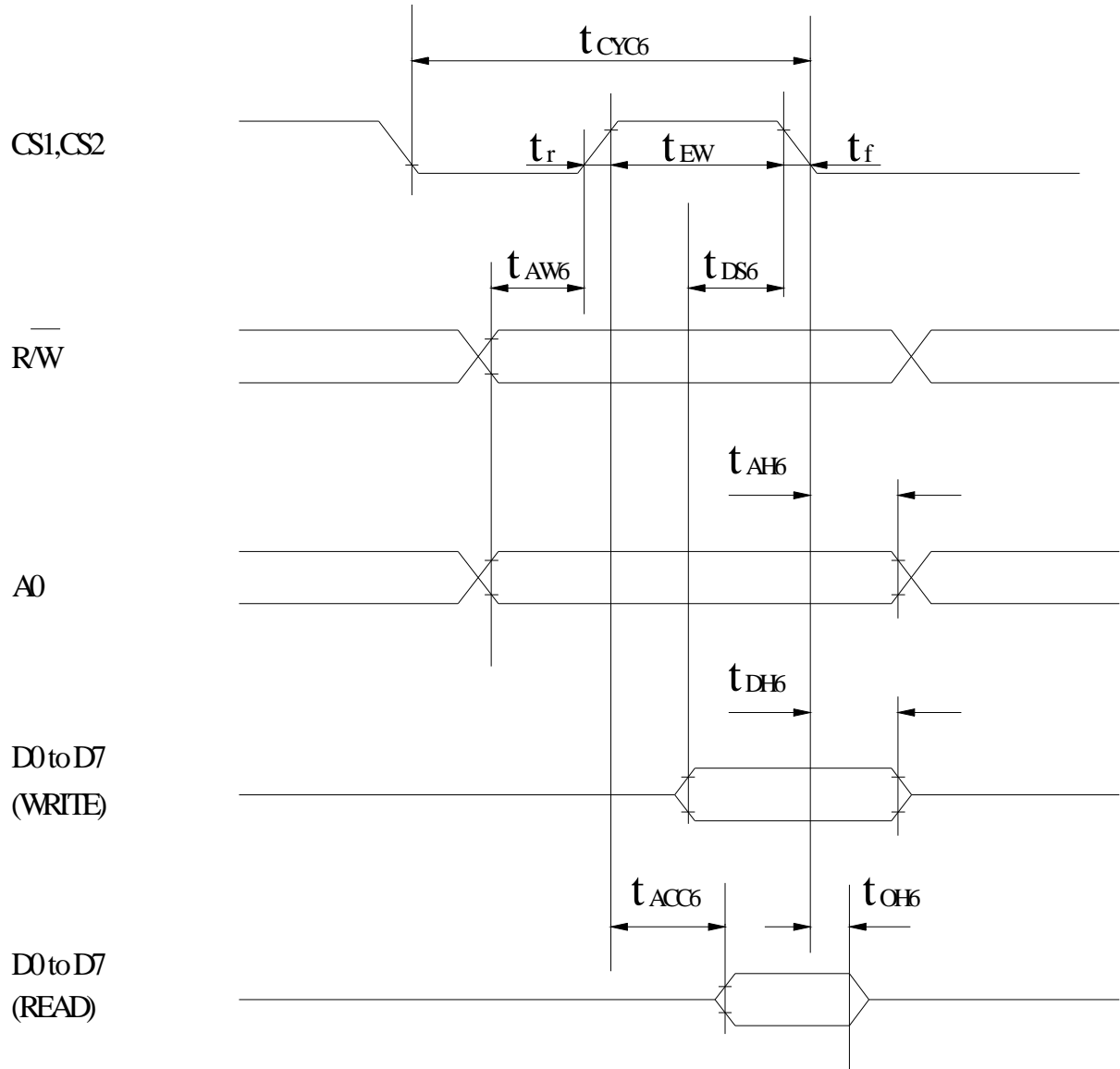

Ta=-20 to 75 deg. C, V_{dd}=-5V±10 unless stated otherwise

Parameter		Symbol	Condition	Rating		Unit	Signal
				Min.	Max.		
System cycle time		t _{CYC6}	-	1000	-	ns	A0,R/W
Address setup time		t _{AW6}	-	20	-	ns	
Address hold time		t _{AH6}	-	10	-	ns	
Data setup time		t _{DS6}	-	80	-	ns	D0 to D7
Data hold time		t _{DH6}	-	10	-	ns	
Output disable time		t _{OH6}	CL=100pF	10	60	ns	
Access time		t _{ACC6}		-	90	ns	
Enable pulsewidth	Read	t _{EW}	-	100	-	ns	CS
	Write		-	80	-	ns	
Rise and fall time		t _r , t _f	-	-	15	ns	-

(V_{dd}=-2.7 to -4.5 V, Ta=-20 to +75°C)

Parameter		Symbol	Condition	Rating		Unit	Signal
				Min.	Max.		
System cycle time		t _{CYC6}	-	2000	-	ns	A0,R/W
Address setup time		t _{AW6}	-	40	-	ns	
Address hold time		t _{AH6}	-	20	-	ns	
Data setup time		t _{DS6}	-	160	-	ns	D0 to D7
Data hold time		t _{DH6}	-	20	-	ns	

Output disable time		t_{OH6}	CL=100pF	20	120	ns	
Access time		t_{ACC6}		-	180	ns	
Enable pulsewidth	Read	t_{EW}	-	200	-	ns	CS
	Write		-	160	-	ns	
Rise and fall time		t_r, t_f	-	-	15	ns	-

12. Quality Assurance

Screen Cosmetic Criteria

No.	Defect	Judgment Criterion	Partition																				
1	Spots	<p>A)Clear</p> <table border="0"> <tr> <td><u>Size: d mm</u></td> <td><u>Acceptable Qty in active area</u></td> </tr> <tr> <td>$d \leq 0.1$</td> <td>Disregard</td> </tr> <tr> <td>$0.1 < d \leq 0.2$</td> <td>6</td> </tr> <tr> <td>$0.2 < d \leq 0.3$</td> <td>2</td> </tr> <tr> <td>$0.3 < d$</td> <td>0</td> </tr> </table> <p>Note: Including pin holes and defective dots which must be within one pixel size.</p> <p>B)Unclear</p> <table border="0"> <tr> <td><u>Size: d mm</u></td> <td><u>Acceptable Qty in active area</u></td> </tr> <tr> <td>$d \leq 0.2$</td> <td>Disregard</td> </tr> <tr> <td>$0.2 < d \leq 0.5$</td> <td>6</td> </tr> <tr> <td>$0.5 < d \leq 0.7$</td> <td>2</td> </tr> <tr> <td>$0.7 < d$</td> <td>0</td> </tr> </table>	<u>Size: d mm</u>	<u>Acceptable Qty in active area</u>	$d \leq 0.1$	Disregard	$0.1 < d \leq 0.2$	6	$0.2 < d \leq 0.3$	2	$0.3 < d$	0	<u>Size: d mm</u>	<u>Acceptable Qty in active area</u>	$d \leq 0.2$	Disregard	$0.2 < d \leq 0.5$	6	$0.5 < d \leq 0.7$	2	$0.7 < d$	0	Minor
<u>Size: d mm</u>	<u>Acceptable Qty in active area</u>																						
$d \leq 0.1$	Disregard																						
$0.1 < d \leq 0.2$	6																						
$0.2 < d \leq 0.3$	2																						
$0.3 < d$	0																						
<u>Size: d mm</u>	<u>Acceptable Qty in active area</u>																						
$d \leq 0.2$	Disregard																						
$0.2 < d \leq 0.5$	6																						
$0.5 < d \leq 0.7$	2																						
$0.7 < d$	0																						
2	Bubbles in Polarize	<table border="0"> <tr> <td><u>Size: d mm</u></td> <td><u>Acceptable Qty in active area</u></td> </tr> <tr> <td>$d \leq 0.3$</td> <td>Disregard</td> </tr> <tr> <td>$0.3 < d \leq 1.0$</td> <td>3</td> </tr> <tr> <td>$1.0 < d \leq 1.5$</td> <td>1</td> </tr> <tr> <td>$1.5 < d$</td> <td>0</td> </tr> </table>	<u>Size: d mm</u>	<u>Acceptable Qty in active area</u>	$d \leq 0.3$	Disregard	$0.3 < d \leq 1.0$	3	$1.0 < d \leq 1.5$	1	$1.5 < d$	0	Minor										
<u>Size: d mm</u>	<u>Acceptable Qty in active area</u>																						
$d \leq 0.3$	Disregard																						
$0.3 < d \leq 1.0$	3																						
$1.0 < d \leq 1.5$	1																						
$1.5 < d$	0																						
3	Scratch	In accordance with spots cosmetic criteria. When the light reflects on the panel surface, the scratches are not to be remarkable.	Minor																				
4	Allowable Density	Above defects should be separated more than 30mm each other.	Minor																				
5	Coloration	Not to be noticeable coloration in the viewing area of the LCD panels. Back-light type should be judged with back-light on state only.	Minor																				

13. Reliability

Content of Reliability Test

Environmental Test			
Test Item	Content of Test	Test Condition	Applicable Standard
High Temperature storage	Endurance test applying the high storage temperature for a long time.	60°C 200hrs	—
Low Temperature storage	Endurance test applying the high storage temperature for a long time.	-10°C 200hrs	—
High Temperature Operation	Endurance test applying the electric stress (Voltage & Current) and the thermal stress to the element for a long time.	50°C 200hrs	—
Low Temperature Operation	Endurance test applying the electric stress under low temperature for a long time.	0°C 200hrs	—
High Temperature/ Humidity Storage	Endurance test applying the high temperature and high humidity storage for a long time.	60°C,90%RH 96hrs	—
High Temperature/ Humidity Operation	Endurance test applying the electric stress (Voltage & Current) and temperature / humidity stress to the element for a long time.	50°C,90%RH 96hrs	—
Temperature Cycle	Endurance test applying the low and high temperature cycle. <div style="text-align: center;"> <p>-10°C 25°C 60°C</p> <p>30min 5min 30min</p> <p>1 cycle</p> </div>	-10°C/60°C 10 cycles	—
Mechanical Test			
Vibration test	Endurance test applying the vibration during transportation and using.	10~22Hz→1.5mmp-p 22~500Hz→1.5G Total 0.5hrs	—
Shock test	Constructional and mechanical endurance test applying the shock during transportation.	50G Half sign wave 11 msedc 3 times of each direction	—
Atmospheric pressure test	Endurance test applying the atmospheric pressure during transportation by air.	115mbar 40hrs	—
Others			
Static electricity test	Endurance test applying the electric stress to the terminal.	VS=800V,RS=1.5kΩ CS=100pF 1 time	—

***Supply voltage for logic system=5V. Supply voltage for LCD system =Operating voltage at 25°C

14. Backlight Information

Specification

PARAMETER	SYMBOL	MIN	TYP	MAX	UNIT	TEST CONDITION
Supply Current	I _{LED}	-	180	360	mA	V=4.2V
Supply Voltage	V	-	4.2	4.6	V	-
Reverse Voltage	V _R	-	-	10	V	-
Luminous Intensity	I _V	-	70	-	CD/M ²	I _{LED} =180mA
Wave Length	λ _p	-	574	-	nm	I _{LED} =180mA
Life Time	-	-	100000	-	Hr.	V≤4.6V
Color	Yellow Green					